

**FINISHER**  
**(Machine Code: A612)**

---

# 1. OVERALL MACHINE INFORMATION

## 1.1 SPECIFICATIONS

Paper Size:	Standard copying/Stack mode Maximum: 11" x 17" /A3 Minimum: 5 1/2" x 8 1/2"/A5 Staple mode Maximum: 11" x 17" /A3 Minimum: 8" x 11"/B5
Paper Weight:	Standard copying/Stack mode 14 ~ 42 lb/52 ~ 157 g/m <sup>2</sup> Staple mode 17 ~ 21 lb/64 ~ 80 g/m <sup>2</sup>
Paper Capacity:	1,500 sheets: 8 1/2" x 11"/A4 or smaller size (20 lb/80 g/m <sup>2</sup> ) 1,000 sheets: 8 1/2" x 14"/B4 or larger size (20 lb/80 g/m <sup>2</sup> )
Stapler Capacity:	8 1/2" x 11"/A4 or smaller size (20 lb/80 g/m <sup>2</sup> ): from 2 to 50 sheets 8 1/2" x 14"/B4 or large size (20 lb/80 g/m <sup>2</sup> ): from 2 to 30 sheets
Staple Replenishment:	Cartridge exchange (5,000 staples/cartridge)
Power Source:	DC 24 V (from copier)
Power Consumption:	48 W (average)
Weight:	35 kg (77.2 lb)

Stapling Position:

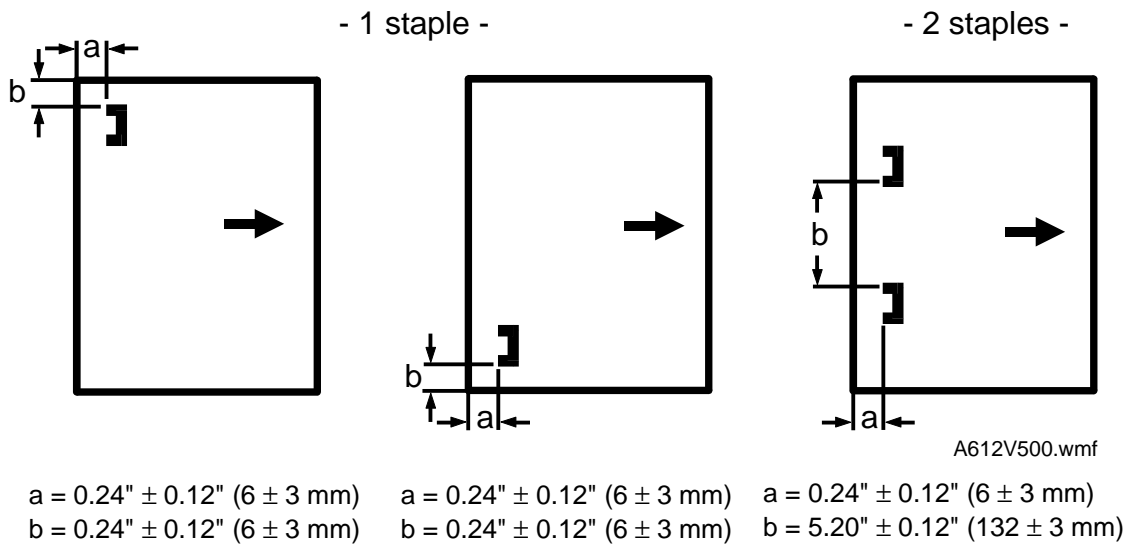

Dimensions:

26.5" x 20.5" x 37.5"  
(671 mm x 514 mm x 950 mm)

## 1.2 MECHANICAL COMPONENT LAYOUT

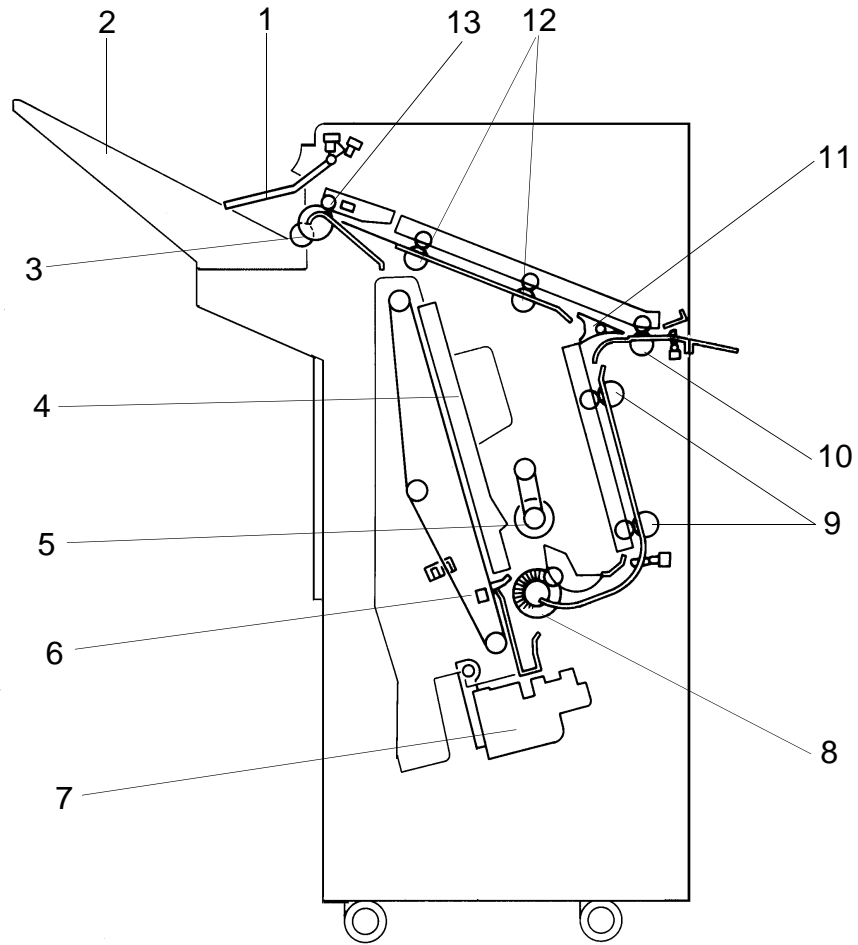

A612V501.img

- |                                  |                             |
|----------------------------------|-----------------------------|
| 1. Stack Height Sensor Feeler    | 8. Alignment Brush Roller   |
| 2. Shift Tray                    | 9. Lower Transport Rollers  |
| 3. Shift Tray Positioning Roller | 10. Entrance Rollers        |
| 4. Jogger Unit                   | 11. Junction Gate           |
| 5. Positioning Roller            | 12. Upper Transport Rollers |
| 6. Stack Feed-out Belt           | 13. Exit Rollers            |
| 7. Stapler Unit                  |                             |

Finisher

### 1.3 ELECTRICAL COMPONENT DESCRIPTION

Refer to the electrical component layout on the reverse side of the point-to-point diagram (on waterproof paper) for the index numbers.

Symbol	Name	Function	Index No.
<b>Motors</b>			
M1	Transport Drive	Drives the transport rollers.	21
M2	Shift Tray Lift	Moves the shift tray up or down.	25
M3	Exit Drive	Drives the exit roller and the shift tray positioning roller.	27
M4	Stack Feed-out	Drives the stack feed-out belt.	5
M5	Jogger	Moves the jogger fences.	19
M6	Stapler Drive	Moves the stapler unit.	17
M7	Shift	Moves the shift tray from side to side.	7
M8	Staple	Drives the staple hammer.	13
M9	Lower Transport Drive	Drives the transport rollers of the stapler section.	22
<b>Sensors</b>			
S1	Entrance	Detects copy paper entering the finisher.	26
S2	Jogger Unit Entrance	Detects copy paper entering the jogger unit.	24
S3	Jogger Unit Paper	Detects copy paper in the jogger unit.	8
S4	Stack Feed-out Belt HP	Detects the home position of the stack feed-out belt.	9
S5	Jogger HP	Detects the jogger home position.	18
S6	Exit	Detects misfeeds in the exit area.	3
S7	Stack Height 1	Detects copy paper stack height in staple mode.	2
S8	Stack Height 2	Detects copy paper stack height in sort/stack mode.	1
S9	Shift Tray Lower Limit	Detects the lower limit of the shift tray position.	15
S10	Staple Hammer HP	Detects the staple hammer home position.	14
S11	Shift Tray Half-Turn	Detects the side-to-side position of the shift tray.	6
S12	Stapler Unit HP	Detects the stapler unit home position.	10

Symbol	Name	Function	Index No.
<b>Switches</b>			
SW1	Front Door Safety	Cuts the dc power when the front door is opened.	28
SW2	Shift Tray Upper Limit	Cuts the power to the shift tray lift motor when the shift tray position is at its upper limit.	4
SW3	Cartridge Set	Detects whether a staple cartridge is installed.	12
SW4	Staple End	Detects staples in the cartridge.	11
<b>Solenoids</b>			
SOL1	Positioning Roller	Lowers the positioning roller in the jogger unit.	20
SOL2	Junction Gate	Drives the junction gate.	23
<b>PCBs</b>			
PCB1	Main Control	Controls overall finisher operation.	16

### 1.4 DRIVE LAYOUT

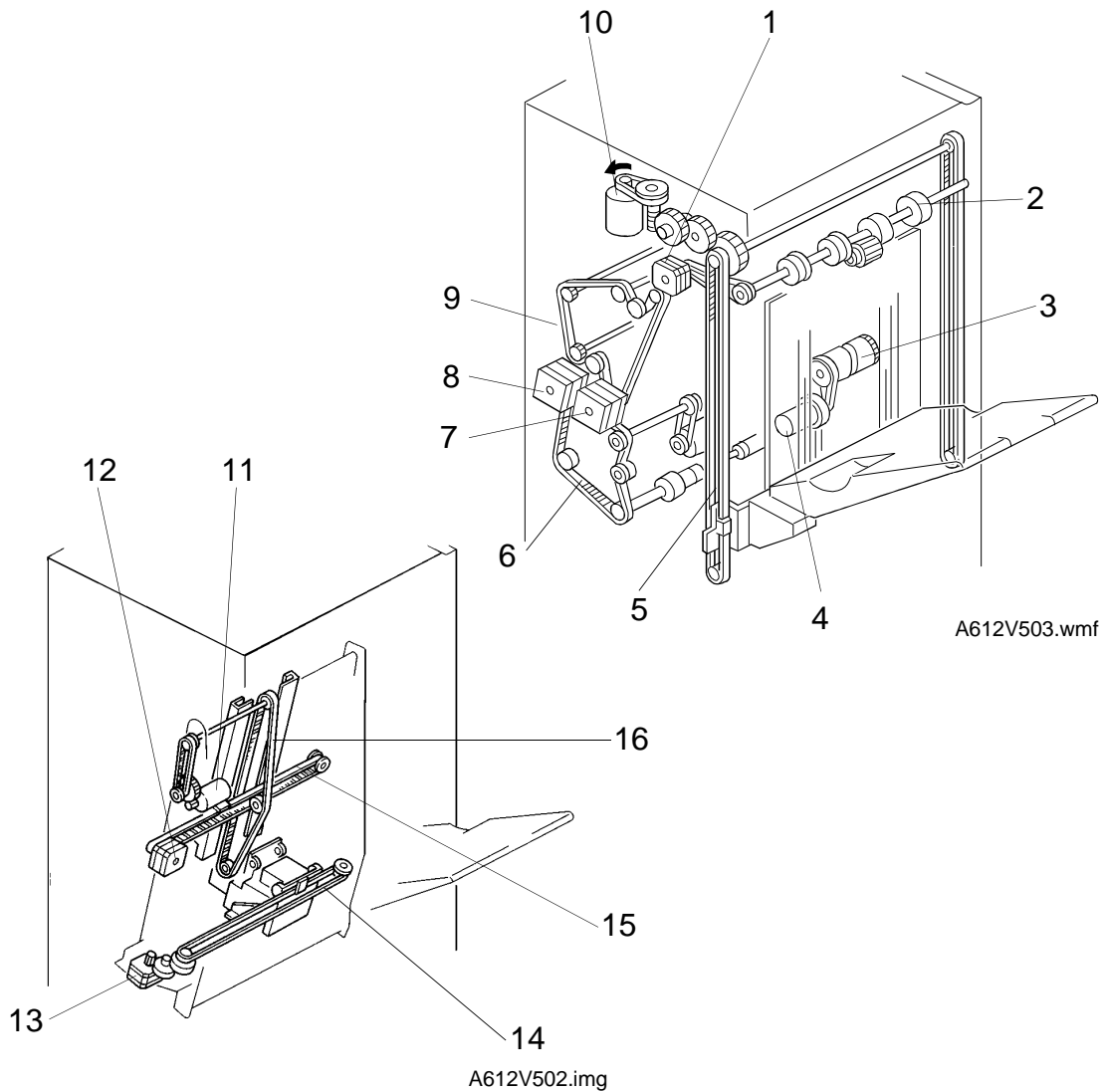

- |                                     |                                |
|-------------------------------------|--------------------------------|
| 1. Exit Drive Motor (M3)            | 9. Upper Transport Drive Belt  |
| 2. Exit Roller                      | 10. Shift Tray Lift Motor (M2) |
| 3. Shift Cam                        | 11. Stack Feed-out Motor (M4)  |
| 4. Shift Motor (M7)                 | 12. Jogger Motor (M5)          |
| 5. Shift Tray Lift Belt             | 13. Stapler Drive Motor (M6)   |
| 6. Lower Transport Drive Belt       | 14. Stapler Drive Belt         |
| 7. Transport Drive Motor (M1)       | 15. Jogger Drive Belt          |
| 8. Lower Transport Drive Motor (M9) | 16. Stack Feed-out Belt        |

## 1.5 BASIC OPERATION

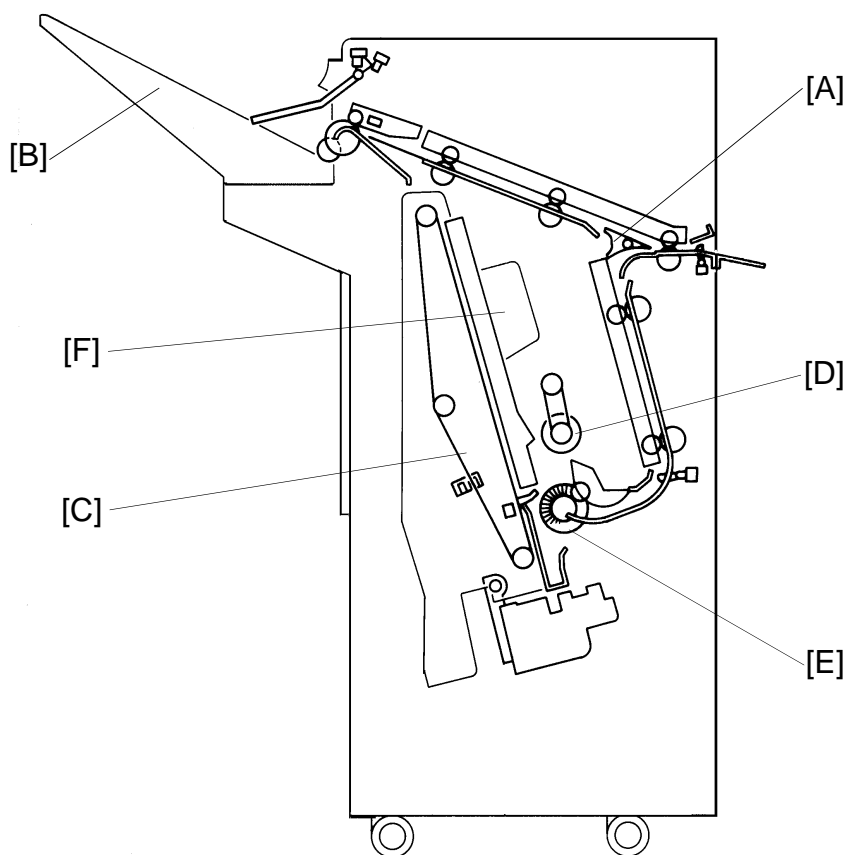

A612V501-2.img

The finisher recognizes the base copier type by receiving the copier's paper exit speed data when the main switch is turned on. The paper transport speed depends on the base copier.

After the copy is completed, the paper is directed to the finisher. If the sort/stack mode is selected, the junction gate [A] directs the paper upwards to send it to the shift tray [B]. In these modes, the shift tray is shifted from side to side to stagger and separate sets of copies. The amount of shift is approximately 30 mm.

When the staple mode is selected, the junction gate directs the paper downwards to send it to the jogger unit [C]. Each time a copy is delivered to the jogger unit, the positioning roller [D], the alignment brush roller [E], and the jogger fences [F] square the stack of copies. After the final copy of the set is squared, the set is stapled, and then delivered to the shift tray.

Finisher



---

## 2. SECTIONAL DESCRIPTIONS

### 2.1 PAPER DELIVERY SWITCHING

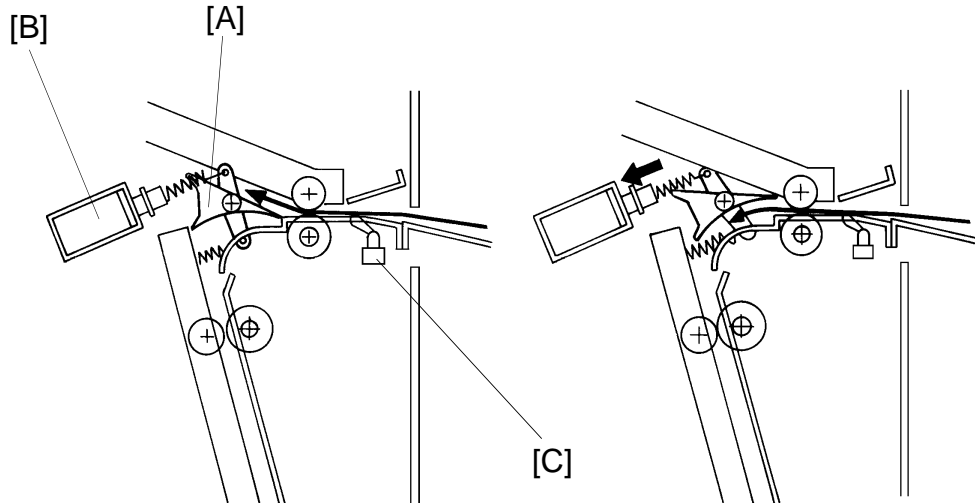

A612D500.img

Depending on the selected finishing mode, the copies are directed up or down by the junction gate [A], which is controlled by a solenoid. This happens after the entrance sensor [C] has been activated.

- (1) When the exit sensor of the copier is activated while in staple mode, the solenoid [B] is energized. Then, the junction gate directs the copies down to send them to the jogger unit.
- (2) When the exit sensor of the copier is activated while in the sort/stack mode, the solenoid stays off. The junction gate directs the copies up to send them to the shift tray.

## 2.2 SHIFT TRAY UP/DOWN MECHANISM

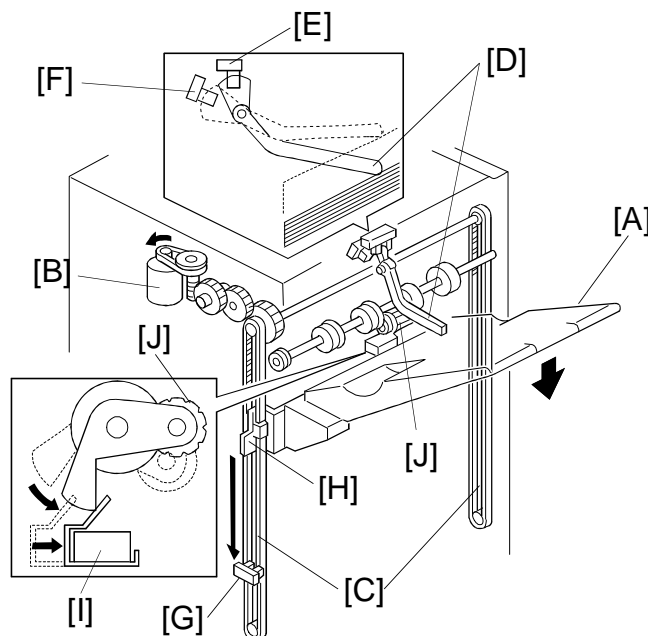

A612D502.wmf

The shift tray lift motor (a dc motor) [B] controls the vertical position of the shift tray [A] through gears and timing belts [C]. When the main switch is turned on, the tray is initialized at the upper position. The tray's upper position is detected when the shift tray pushes up actuator [D] until the actuator has just left the stack height sensor 1 [E], and is now between the two sensors [E] and [F].

During copying, the actuator feeler gradually rises as the copy stack grows, and the actuator gradually moves towards stack height sensor 2. In sort/stack mode, if the actuator remains inside stack height sensor 2 [F] for 4 s, the shift tray lift motor lowers the tray unit for 50 ms. In staple mode, if the actuator leaves stack height sensor 1 for 4 s during a copy run, the motor lowers the tray until stack height sensor 1 is actuated. This means the tray lowers earlier in staple mode, to prevent problems caused by sudden arrivals of stapled stacks of paper on the tray (stapling is done inside the machine, and the stapled copy is fed out to the tray; the second copy may suddenly exceed the space currently available on the tray).

For both modes, the shift tray will rise when the user takes the stack of paper from the tray during copying.

When the tray reaches its lower limit, actuator [H] enters the lower limit sensor [G], and copying stops. After copying ends and the machine stops, the tray is raised to its uppermost position 4 s after the copies are removed.

The shift tray upper limit switch [I] prevents the drive gears from being damaged if stack height sensor 1 fails. When the shift tray pushes up the shift tray positioning roller [J], the switch cuts the power to the shift tray lift motor.

## 2.3 SHIFT TRAY SIDE-TO-SIDE SHIFT MECHANISM

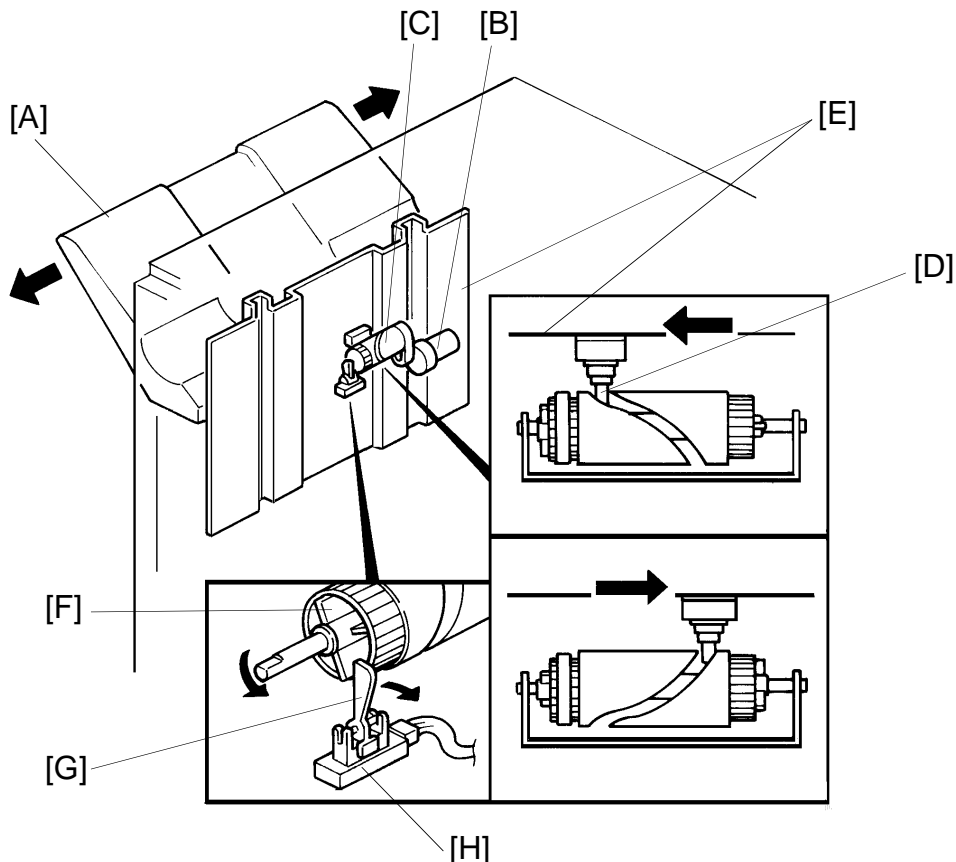

A162D503.img

In the sort/stack mode, the shift tray [A] moves from side to side to stagger and separate the sets of copies.

The horizontal position of the shift tray is controlled by the shift motor (dc motor) [B] and the shift cam (helical cam) [C]. After one set of originals is copied and delivered to the shift tray, the shift motor [B] starts rotating, driving the shift cam through the timing belt. The pin [D] fixed to the shift tray base plate [E] is positioned in the groove on the shift cam, creating the side-to-side movement required to stagger the copies.

When the shift cam has rotated 180 degrees (when the tray is fully shifted across), the plate [F] on the shift cam pushes the actuator [G] of the shift tray half-turn sensor [H] and the shift motor stops. The next set of copies is then delivered. The motor rotates, repeating the same process and moving the tray back to the previous position.

## 2.4 STAPLE UNIT PAPER POSITIONING

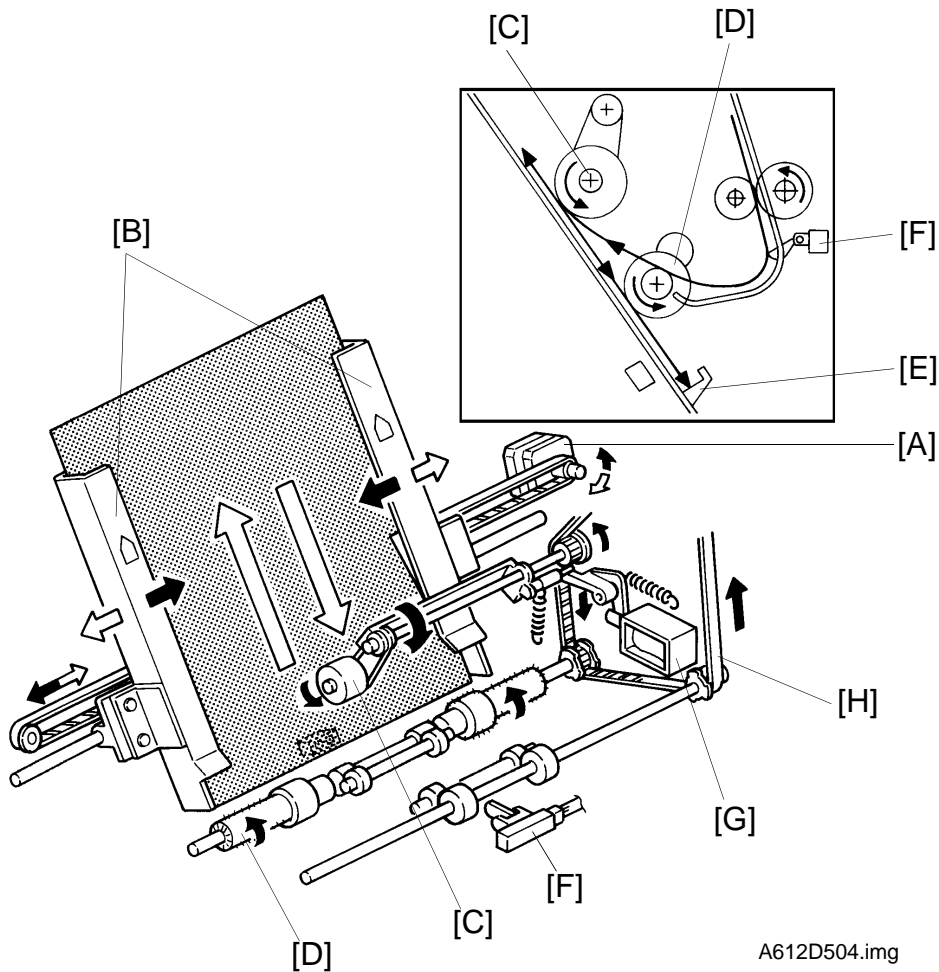

A612D504.img

In staple mode, each sheet of copy paper is vertically and horizontally aligned when it arrives in the jogger unit.

For horizontal paper alignment, the jogger motor [A] moves both the front and the rear jogger fences [B] to align the copies.

For vertical paper alignment, the positioning roller [C] and the alignment brush roller [D] push the copy against the stack stopper [E].

After the trailing edge of the copy passes the jogger unit entrance sensor [F], the positioning roller solenoid [G] is energized for 280 ms to push the positioning roller into contact with the paper. The positioning roller rotates to push the paper back and align the trailing edge of the paper against the stack stopper. Both the positioning roller and the alignment brush roller are driven by the lower transport drive motor through the timing belt [H].

Finisher

## 2.5 JOGGER MOVEMENT

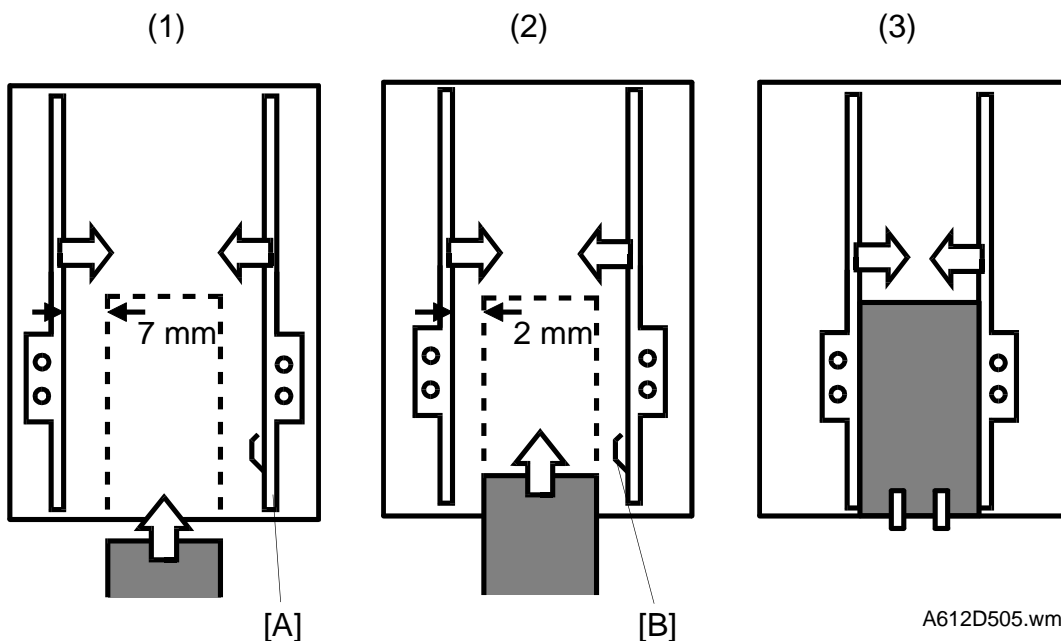

A612D505.wmf

When the Start key is pressed, the copier sends the paper size information to the finisher. In accordance with that data, the jogger motor (stepper motor) starts rotating to position the front and rear jogger fences [A] 7 mm away from the selected paper's edges. (1)

After the trailing edge of the copy passes the jogger unit entrance sensor, each jogger fence moves inward 5 mm. They stop 2 mm away from the paper edges. (2)

Just after the positioning roller pushes the copy back, each jogger fence moves inward 2 mm more so that the leaf spring [B] on the rear jogger fence pushes the copy side edge slightly. (3)

After a copy is stacked in the jogger tray, the jogger fences move back 7 mm from the copy edge for the next copy.

## 2.6 STAPLER

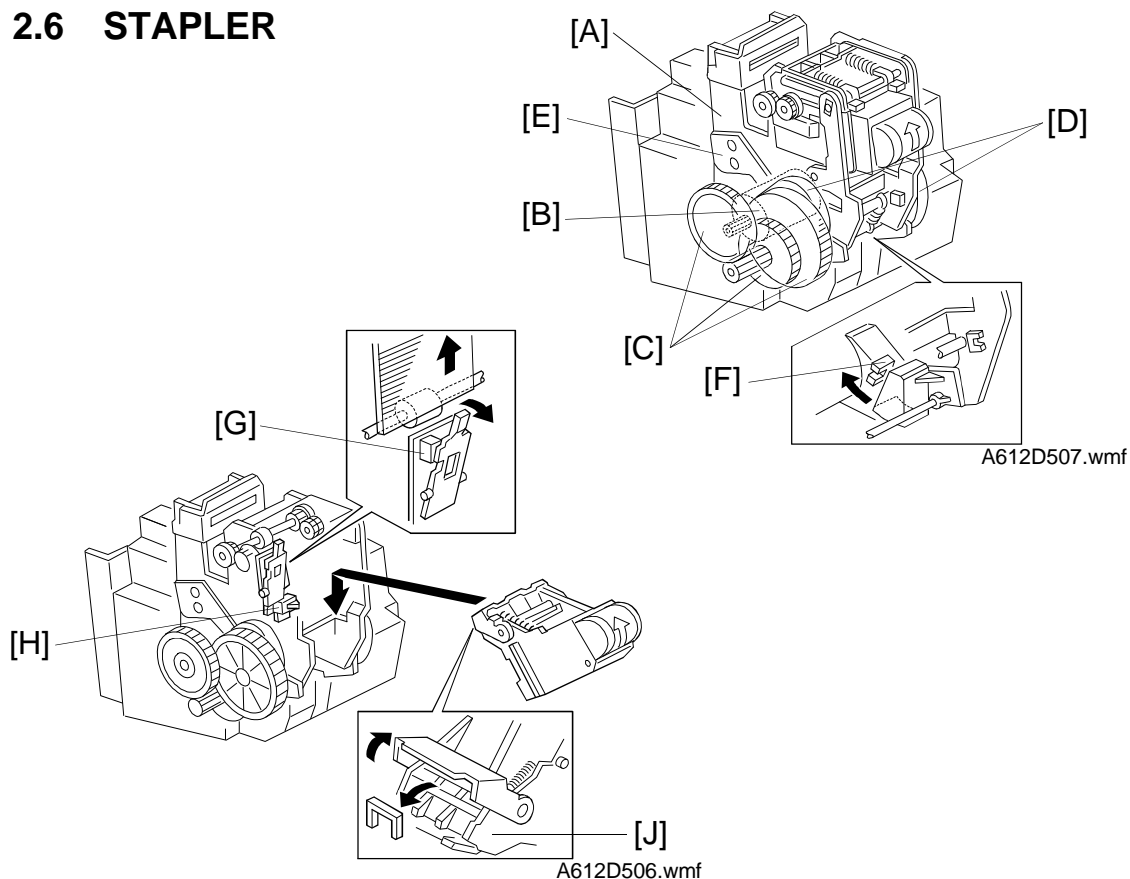

The staple hammer [A] is driven by the stapler motor [B] via gears [C], two eccentric cams [D], and two links [E].

When the aligned copies are brought to the stapling position by the positioning roller, alignment brush roller and jogger fences, the stapler motor starts. When the cams complete one rotation, the staple hammer home position sensor [F] turns on, detecting the end of the stapling operation. The stapler motor then stops.

There are two sensors in the stapler unit. One is the staple end switch [G] for detecting staple end conditions (it detects when there is only one sheet of staples left in the cartridge). The other is the cartridge set switch [H] for detecting whether a staple cartridge is installed.

When a staple end or no staple cartridge condition is detected, a message is displayed advising the operator to install a staple cartridge. If this condition is detected during a copy job, the indication will appear, but will not stop the copy job in any way.

The staple cartridge has a clinch area [J], in which the jammed staples are left. Operators can remove the jammed staples from the cartridge.

## 2.7 STAPLER UNIT SIDE-TO-SIDE MOVEMENT

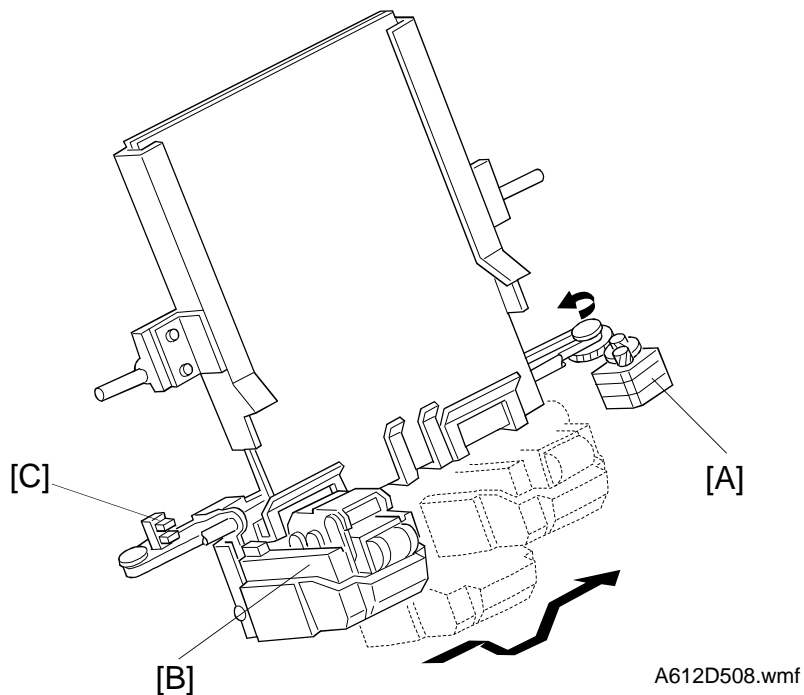

Customers can select one of the following three different staple modes:

- Staple 1: Top left
- Staple 2: Bottom left
- Staple 3: Top/Bottom left

The stapler drive motor [A] (a stepper motor) moves the stapler unit [B] from side to side. After the Start key is pressed, the stapler moves from its home position to the staple position.

If staple mode 3 is selected, the stapler unit moves to the front staple position first, then moves to the rear staple position. However, for the next copy set, it staples in the reverse order; that is, at the rear side first and then at the front.

After the job is completed, the stapler unit moves back to its home position. (The stapler unit home position sensor [C] is actuated.)

## 2.8 FEED-OUT TO THE SHIFT TRAY

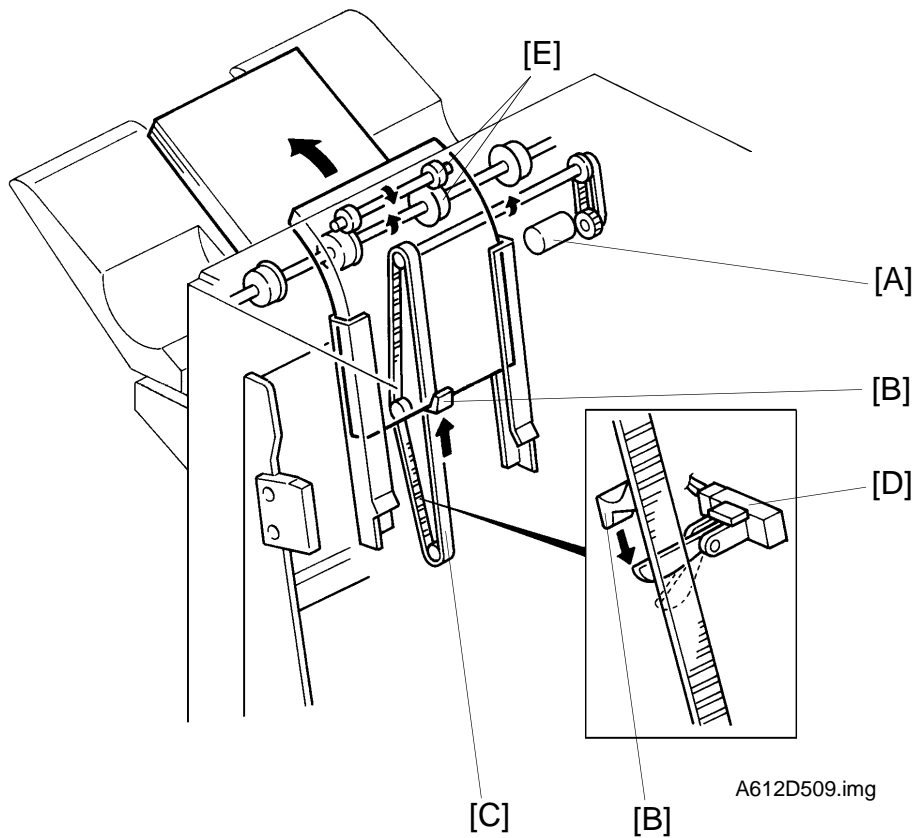

After the copies have been stapled, the stack feed-out motor [A] starts. The pawl [B] on the stack feed-out belt [C] transports the set of stapled copies up, and feeds it to the shift tray. Approximately 0.6 second after the stack feed-out motor starts, the motor stops for 400 ms. At this moment, the exit rollers catch the stapled copies to feed them out to the shift tray. Then the motor rotates again until the pawl actuates the stack feed-out belt home position sensor [D].

The exit drive motor starts to drive the exit rollers [E] when the first copy activates the entrance sensor. The exit drive motor speed is reduced just before each sheet of copy paper is completely fed out. This is to ensure an even copy stack.



### 3. INSTALLATION PROCEDURE

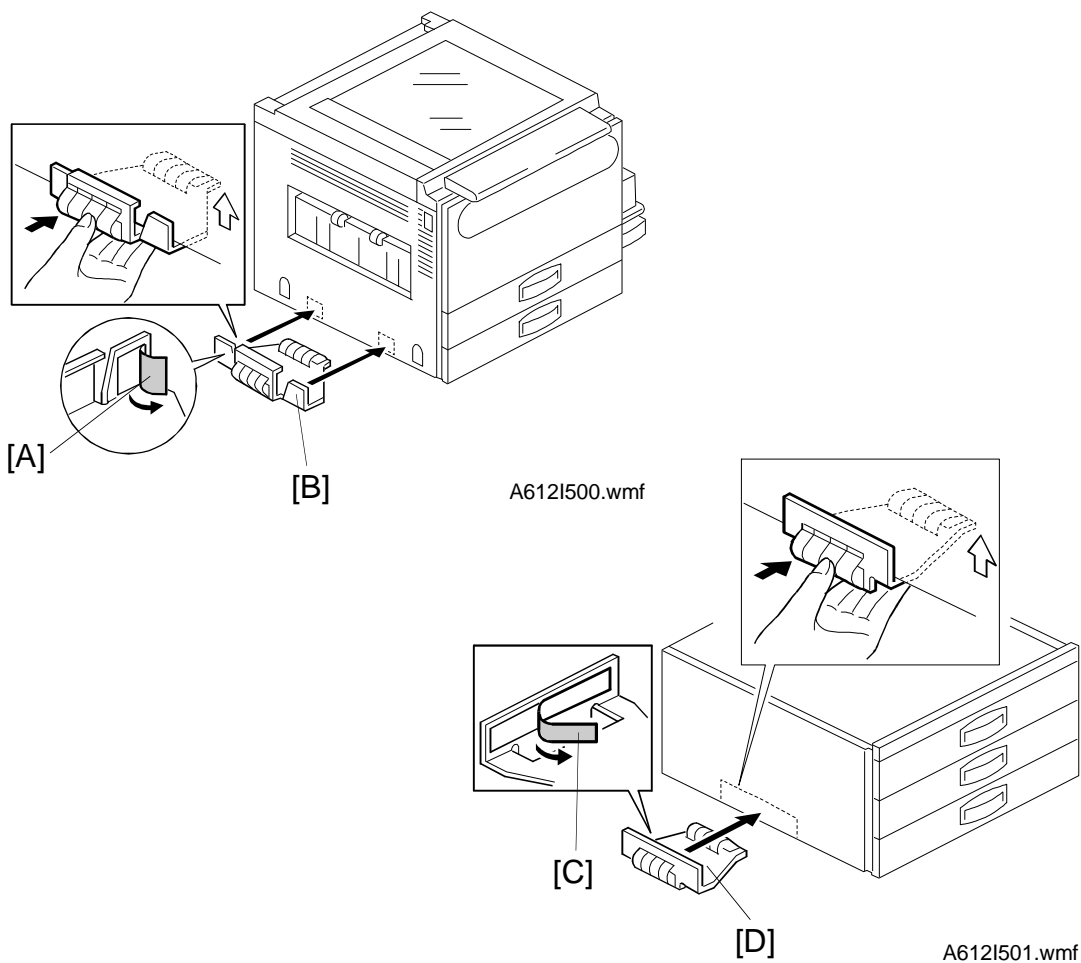

**⚠ CAUTION**  
**Unplug the power cord before beginning the following procedure.**

**In European countries only (step 1 ~ 4)**

1. Peel off the backing [A] of the double sided tape affixed to the copier grounding plate [B].
2. Attach the copier grounding plate to the copier as shown.
3. Peel off the backing [C] of the double sided tape affixed to the PFU grounding plate [D].
4. Attach the PFU grounding plate to the paper feed unit as shown.

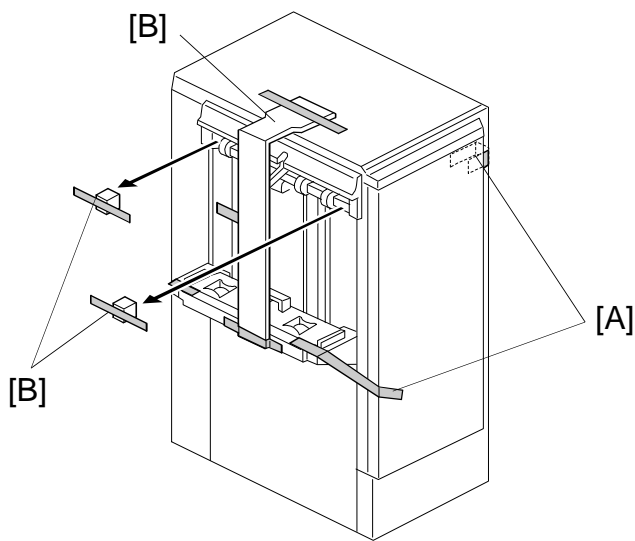

A612I502.wmf

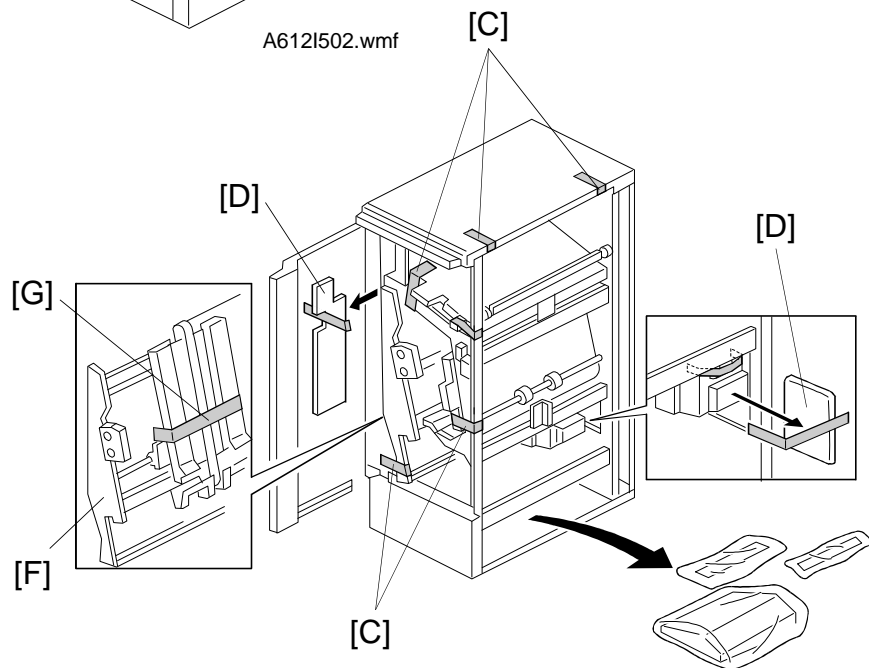

A612I503.wmf

5. Remove the strips of tape [A] and the cushoins [B].
6. Open the front door and remove the strips of tape [C] and cushions [D].
7. Extend the staple unit [F].
8. Remove the strip of tape [G].

**Finisher**

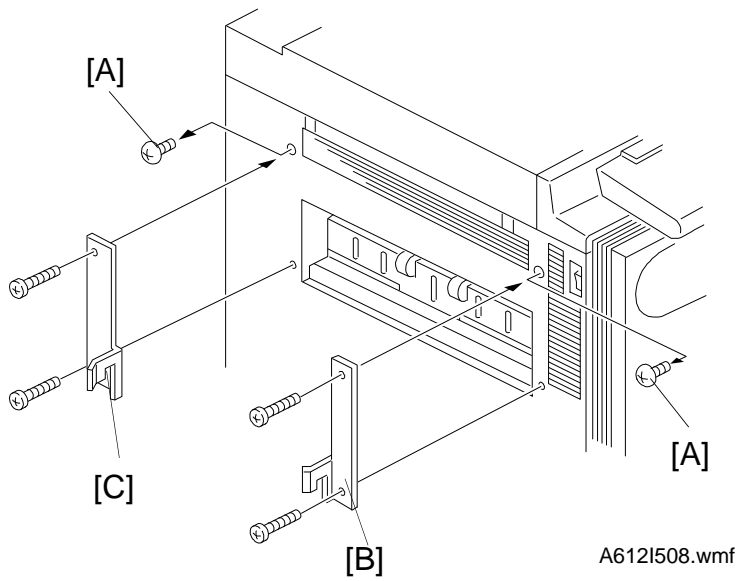

A612I508.wmf

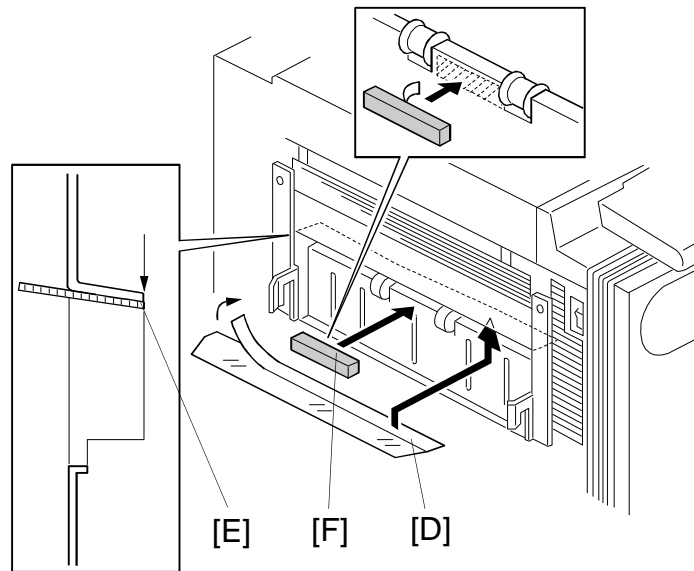

A612I504.wmf

9. Remove the screws [A] from the left cover.
10. Install the front connecting bracket [B] (2 screws– M4 x 12) and the rear connecting bracket [C] (2 screws– M4 x 12).
11. Affix the mylar strip [D] to the copy exit area, as shown.  
**NOTE:** Carefully align the edge of the cover [E] with the mylar guide.
12. Affix the cushion [F] to the lower exit plate, as shown.



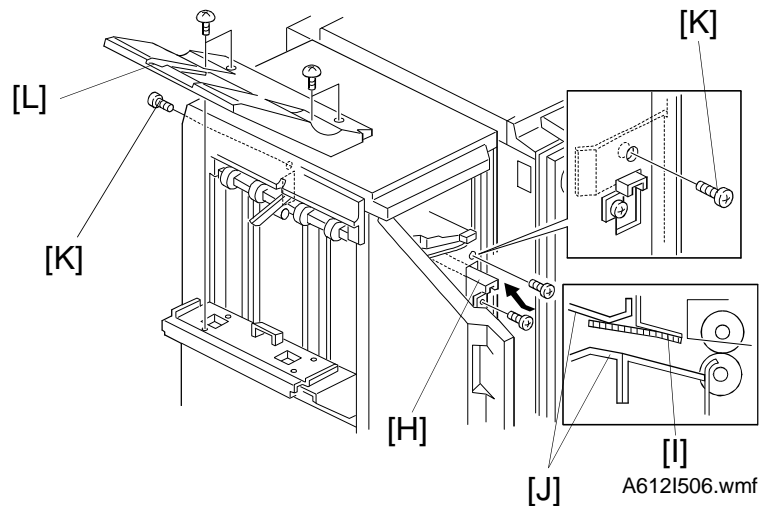
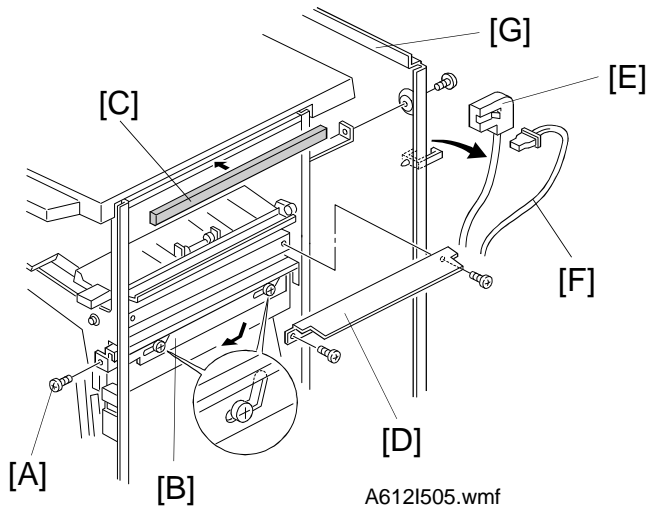

13. Open the front door of the finisher and remove the screw [A], which secures the locking lever [B]. Then pull the locking lever (This causes the lever to move out and down).
14. Affix the cushion [C] on the metal stay (not on the cover) as shown.
15. Install the entrance guide plate [D] (2 screws -M4 x 6).
16. Open the two clamps; remove the cable [E] and the fiber optic cable [F].
17. Remove the rear cover [G] (6 screws).
18. Align and install the finisher to the connecting brackets. Lock them in place by raising the locking lever [H].
 

**NOTE:** Ensure the mylar strip [I] is located between the guides [J].
19. Secure the locking lever [H] (1 screw) and the finisher (2 screws [K]).
20. Install the shift tray [L] (4 screws – M4 x 8).

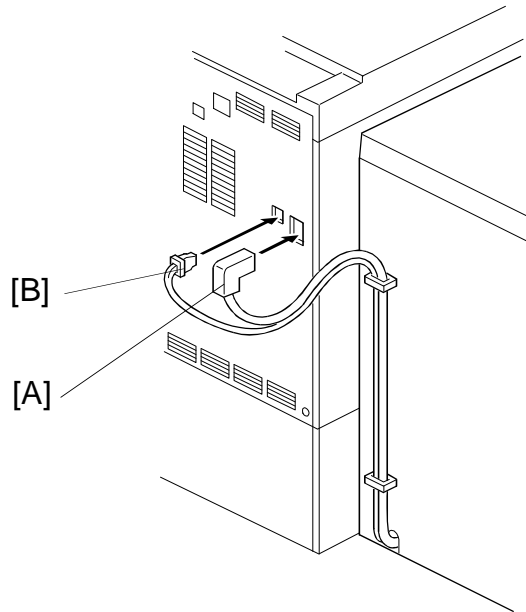

A612I507.wmf

19. Reinstall the rear cover.
20. Connect the cable [A] and the fiber optic connector [B].
21. Plug in the copier.
22. Turn on the main switch and test the newly installed finisher's operation.

**NOTE:** The copier automatically recognizes that the finisher has been installed. The stapler will begin stapling after about 10 copies (This allows the first staple to come to the proper position in the cartridge).

## 4. SERVICE TABLES

### 4.1 TEST POINT TABLE (MAIN BOARD)

Number	Function
TP100	GND
TP101	5 V
TP102	24 V

### 4.2 FUSE TABLE

Number	Rated Current	Location
Fuse 100	5A	Main PCB

### 4.3 LED TABLE

LED No.	ON Status During Adjustment
LED100	Stack feed-out motor speed is normal.

**\*NOTE:** Adjust the speed of the stack feed-out motor by setting DIP SW 100/101 to Motor Test Mode (see below). Then adjust VR100. If the motor speed is either too high or too low, LED 100 will blink.

### 4.4 DIP SW TABLE

#### 4.4.1 Factory Setting

DIP SW100				DIP SW101			
1	2	3	4	1	2	3	4
0	0	0	0	0	0	0	0

#### 4.4.2 Motor Test Mode

DIP SW100				DIP SW101				Motor
1	2	3	4	1	2	3	4	
1	1	0	1	1	0	0	0	Stack Feed-out Motor

After setting DIP SW100, turn on switch 1 of DIP SW101 to start the stack feed-out motor. Turn off DIP SW101-1 to stop the motor.

**4.4.3 Free Run Test Mode Without Paper**

DIP SW100				DIP SW101				Test Type
1	2	3	4	1	2	3	4	
1	1	1	0	1	0	0	0	Shift tray mode
1	1	1	0	0	1	0	0	Staple mode - Top left
1	1	1	0	0	0	1	0	Staple mode - Bottom left
1	1	1	0	0	0	0	1	Staple mode - Top/Bottom left

Start the free run test mode by changing DIP SW100 then DIP SW101 to select the required test as shown in the table.

In shift tray mode, the finisher works as if 10 sets of 5 LT pages are being sorted. The machine then initializes itself and repeats the operation.

In staple mode, the finisher works as if 5 sets of 5 LT pages are being stapled and delivered. The machine then initializes itself and repeats the operation.

## 5. REPLACEMENT AND ADJUSTMENT

### 5.1 EXTERIOR REMOVAL

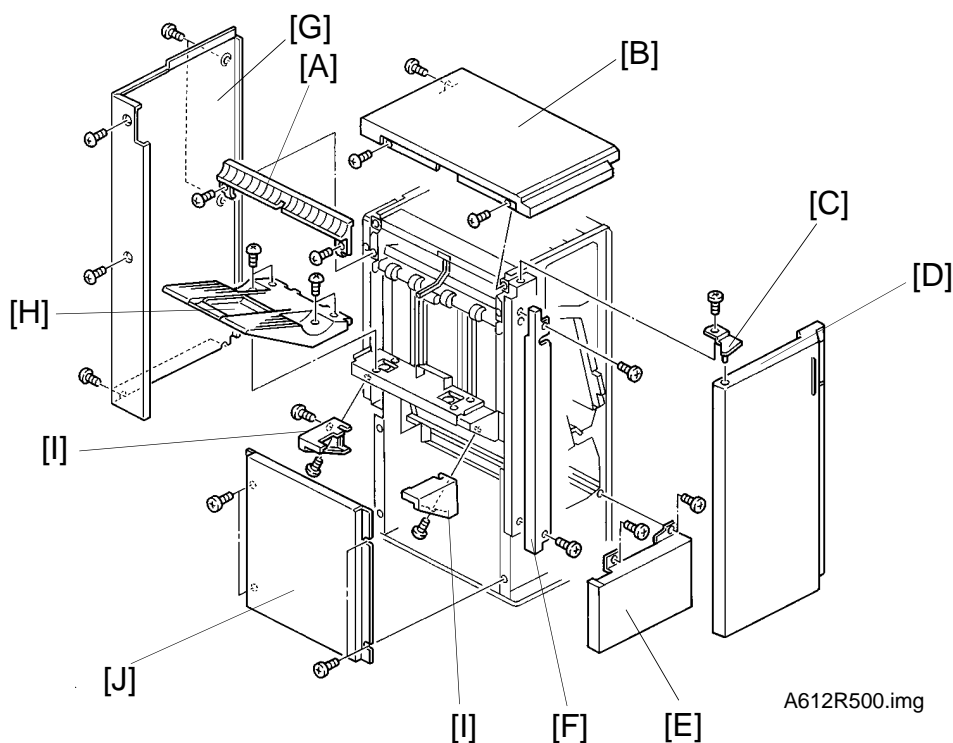

1. Remove the left upper cover [A] (2 screws).
2. Remove the upper cover [B] (3 screws).
3. Remove the upper door bracket [C] (1 screw) and remove the front door [D].
4. Remove the lower front cover [E] (2 screws).
5. Remove the front shift cover [F] (2 screws).
6. Remove the rear cover [G] (6 screws).
7. Remove the shift tray [H] (4 screws).

**NOTE:** The shift tray cannot be removed if it is at its uppermost position. Bring the shift tray down by manually turning the shift tray lift motor timing belt.

8. Remove the front and rear tray cover [I] (1 screw at the front, 2 screws at the rear).
9. Remove the left cover [J] (4 screws).



## 5.2 ALIGNMENT BRUSH ROLLER REPLACEMENT

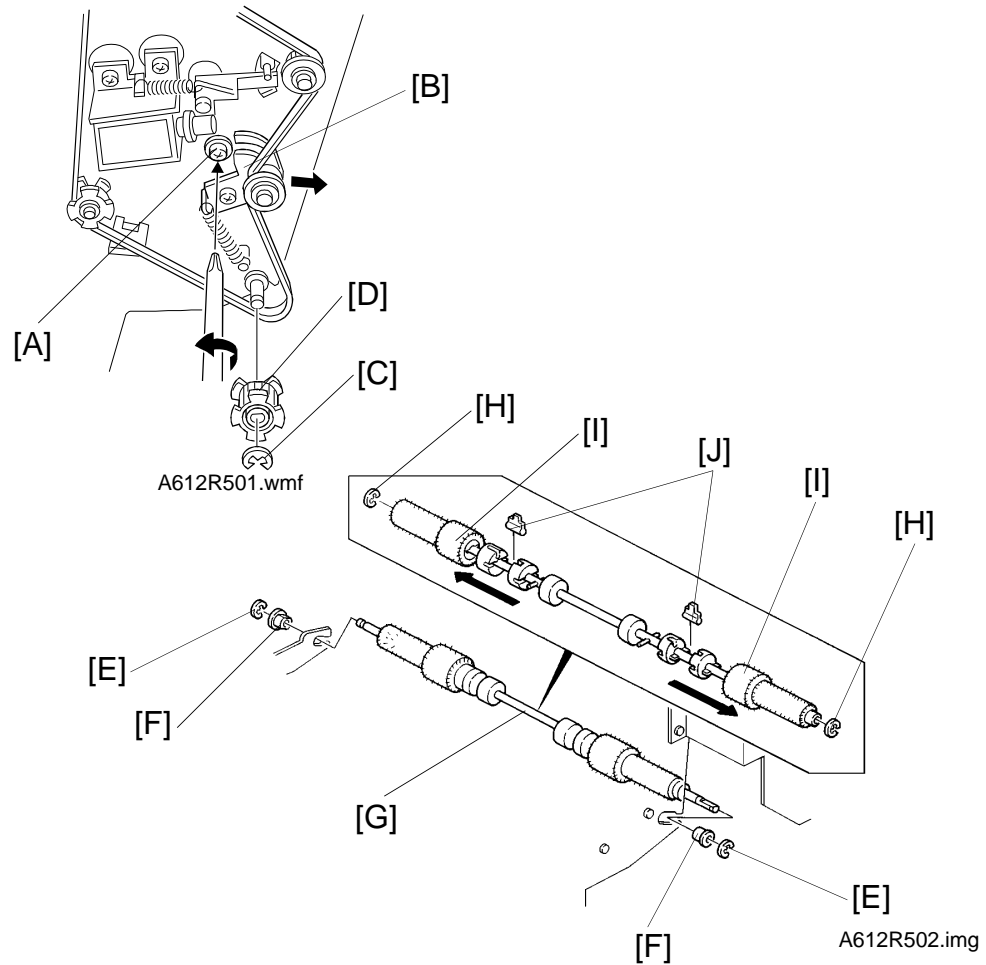

1. Open the front door and slide out the jogger unit.
2. Remove the rear cover.
3. Loosen the screw [A] and flip the tension bracket [B] to release the tension of the lower transport drive belt.
4. Remove the E-ring [C], slide out the pulley [D], remove 2 E-rings [E], then remove 2 bushings [F].
 

**NOTE:** When reinstalling, the metal bushing goes at the front side.
5. Remove the alignment brush roller assembly [G].
6. Remove the 2 E-rings [H] and the brush rollers [I].
 

**NOTE:** Do not lose the link keys [J].

### 5.3 STACK HEIGHT SENSOR REPLACEMENT

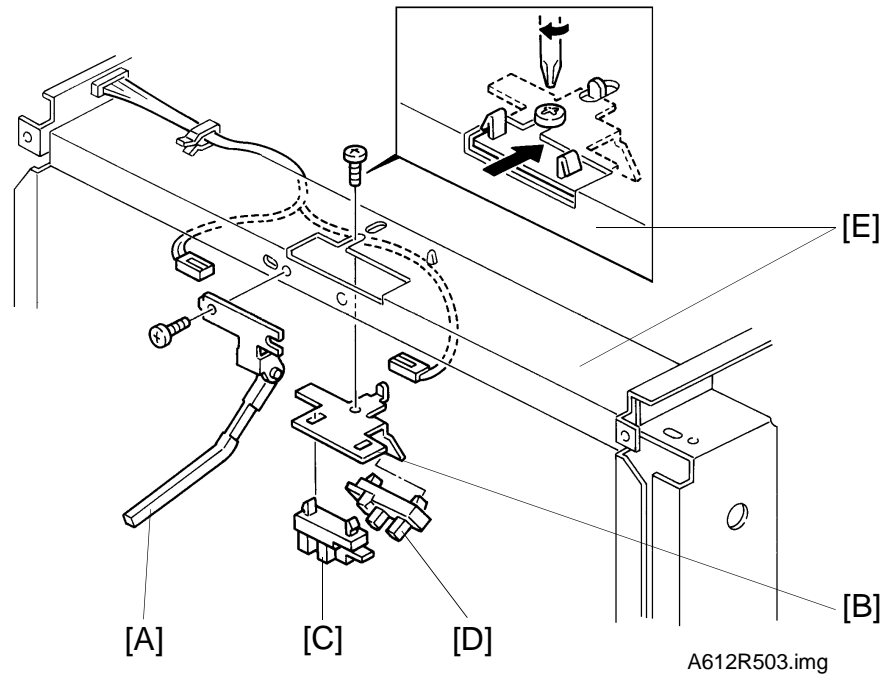

1. Remove the upper cover.
2. Remove the stack height sensor actuator [A] (1 screw).
3. Remove the bracket [B] (1 screw, 2 connectors).
4. Replace stack height sensor 1 [C] and stack height sensor 2 [D].

**NOTE:** When reinstalling the bracket [B], align the edge of the bracket with the stay [E].

## 5.4 POSITIONING ROLLER REPLACEMENT

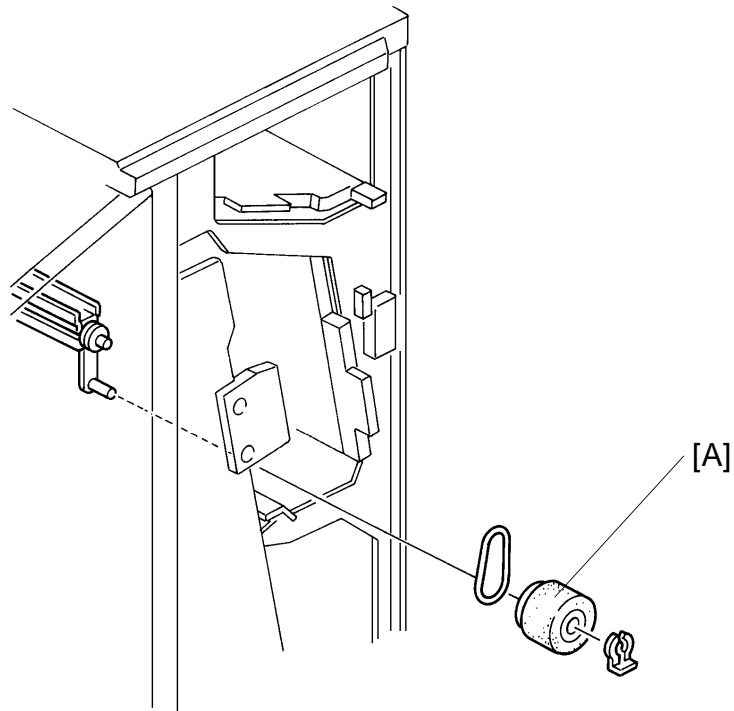

A612R504.img

1. Open the front door and slide out the jogger unit.
2. Remove the positioning roller [A] (1 snap ring).

## 5.5 BELT TENSION ADJUSTMENT

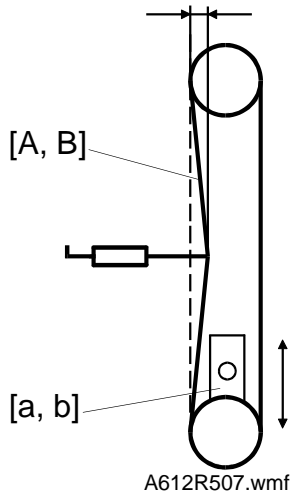
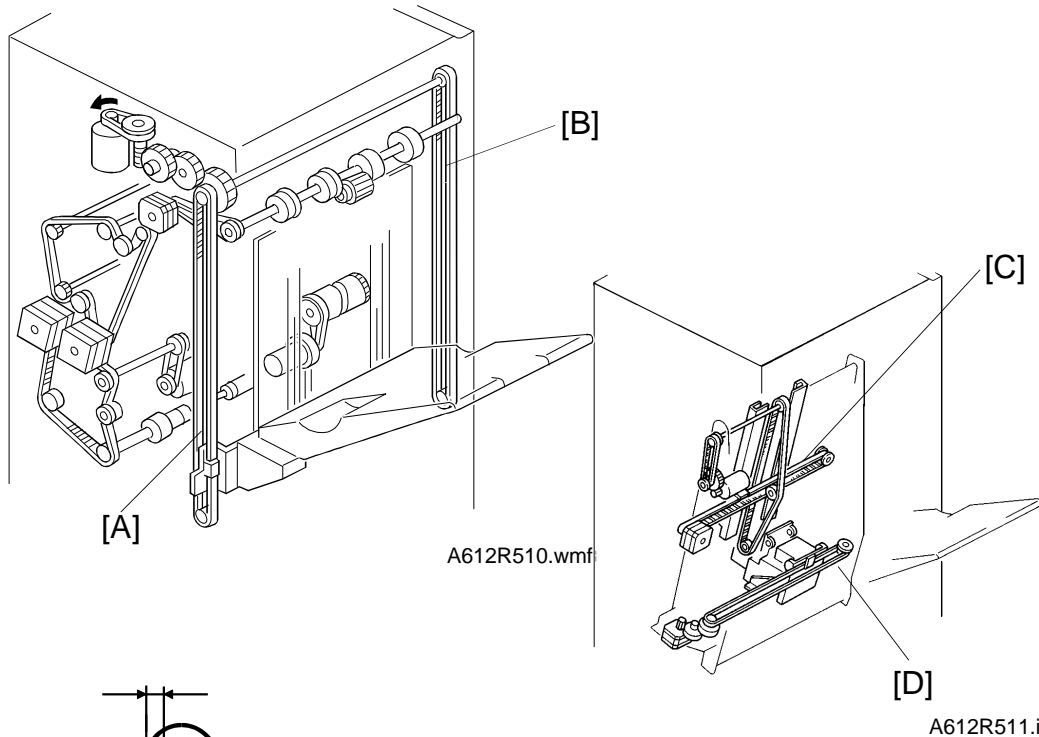

1. Remove the rear cover and adjust the tension of belt [A] with tightener [a]. Remove the left upper cover, the upper cover, the front door, the front shift cover and the lower front cover (2 screws). Adjust the belt [B] with tightener [b].

Standard: 6 mm deflection at  $50 \pm 20$  g pressure.

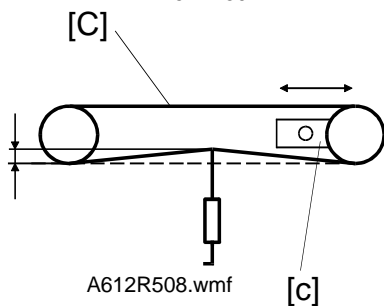

2. Open the front door and slide out the jogger unit. Adjust the tension of belt [C] with tightener [c].

Standard: 8 mm deflection at  $100 \pm 30$  g pressure.

**Finisher**

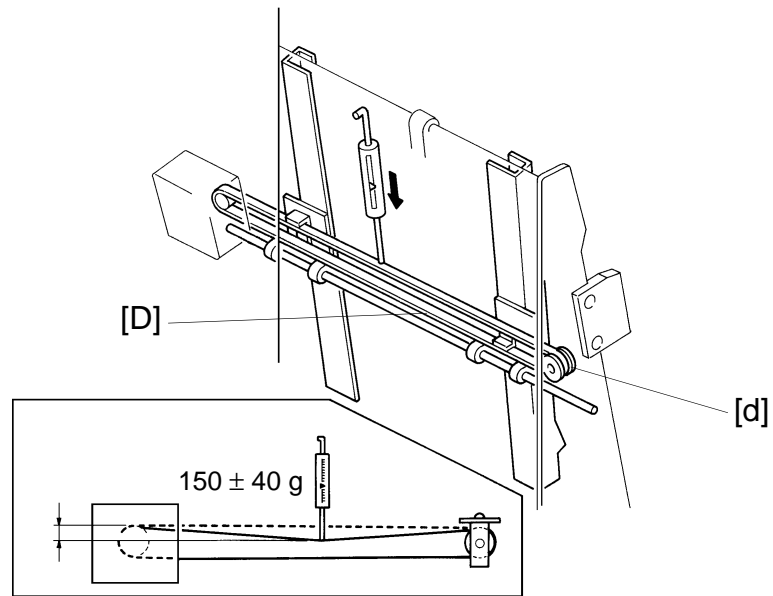

A612R509.img

3. Open the front door and slide out the jogger unit. Adjust the tension of belt [D] with tightener [d].  
Standard: 8 mm deflection at  $150 \pm 40$  g pressure.

# FINISHER (A612) ELECTRICAL COMPONENTS

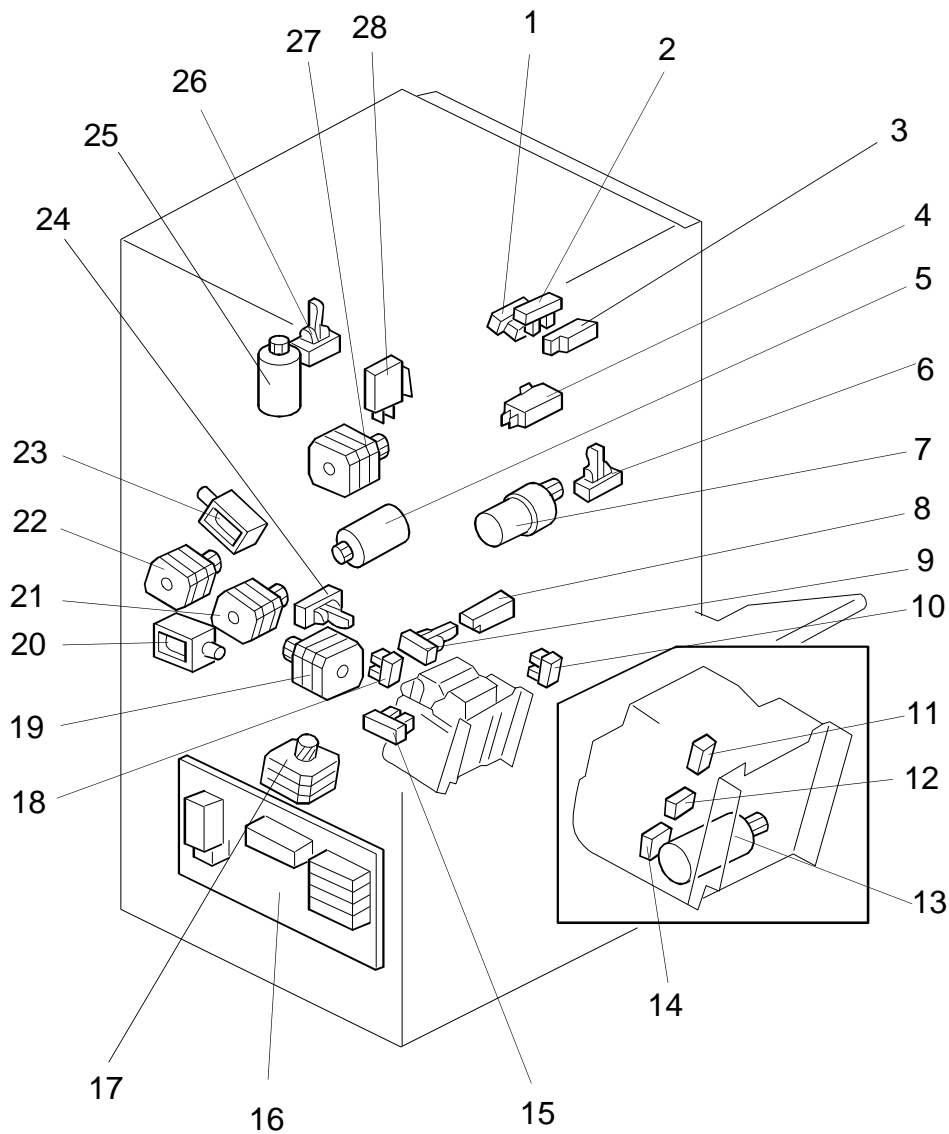

<b>Index. No.</b>	<b>Index No.</b>	<b>Description</b>	<b>P to P</b>
1	S8	Stack Height 2 Sensor	F2
2	S7	Stack Height 1 Sensor	G2
3	S6	Exit Sensor	G2
4	SW2	Shift Tray Upper Limit Switch	F18
5	M4	Stack Feed-out Motor	J16
6	S11	Shift Tray Half Turn Sensor	F2
7	M7	Shift Motor	E18
8	S3	Jogger Unit Paper Sensor	H4
9	S4	Stack Feed-out Belt HP Sensor	J4
10	S12	Stapler Unit HP Sensor	I4
11	SW4	Staple End Switch	L3
12	SW3	Cartridge Set Switch	L3
13	M8	Staple Motor	K2
14	S10	Staple Hammer HP Sensor	L3
15	S9	Shift Tray Lower Limit Sensor	E4
16	PCB1	Main Control Board	C10
17	M6	Staple Drive Motor	H17
18	S5	Jogger HP Sensor	I4
19	M5	Jogger Motor	I17
20	SOL1	Positioning Roller Solenoid	F17
21	M1	Transport Drive Motor	C17
22	M9	Lower Transport Drive Motor	K17
23	SOL2	Junction Gate Solenoid	D17
24	S2	Jogger Unit Entrance Sensor	E4
25	M2	Shift Tray Lift Motor	D2
26	S1	Entrance Sensor	D4
27	M3	Exit Drive Motor	G17
28	SW1	Front Door Safety Switch	L17